

40Gb/s QSFP+ ER4 Optical Transceiver NS-QSFP+40GBase-ER4

Features

- Compliant with 40G Ethernet IEEE802.3ba and 40GBASE-ER4 Standard
- QSFP+ MSA compliant
- Compliant with QDR/DDR Infiniband data rate
- Up to 11.2Gb/s data rate per wavelength
- 4 CWDM lanes MUX/DEMUX design
- Up to 40km transmission on single mode fiber (SMF)
- Operating case temperature: 0 to 70 °C
- Maximum power consumption 2.5W
- LC duplex connector
- RoHS compliant

Applications

- 40GBASE-ER4 Ethernet Links
- Infiniband QDR and DDR interconnects
- Client-side 40G Telecom connections

Description

This product is a transceiver module designed for up to 40km optical communication applications. The design is compliant to 40GBASE-ER4 of the IEEE P802.3ba standard. The module converts 4 inputs channels (ch) of 10Gb/s electrical data to 4 CWDM optical signals, and multiplexes them into a single channel for 40Gb/s optical transmission. Reversely, on the receiver side, the module optically de-multiplexes a 40Gb/s input into 4 CWDM channels signals, and converts them to 4 channel output electrical data.

The central wavelengths of the 4 CWDM channels are 1271, 1291, 1311 and 1331nm as members of the CWDM wavelength grid defined in ITU-T G.694.2. It contains a duplex LC connector for the optical interface and a 38-pin connector for the electrical interface. To minimize the optical dispersion in the long-haul system, single-mode fiber (SMF) has to be applied in this module.

The product is designed with form factor, optical/electrical connection and digital diagnostic interface according to the QSFP+ Multi-Source Agreement (MSA). It has been designed to meet the harshest external operating conditions including temperature, humidity and EMI interference.

Functional Description

This product converts the 4-channel 10Gb/s electrical input data into CWDM optical signals (light), by a driven 4-wavelength Distributed Feedback Laser (DFB) array. The light is combined by the MUX parts as a 40Gb/s data, propagating out of the transmitter module from the SMF. The receiver module accepts the 40Gb/s CWDM optical signals input, and de-multiplexes it into 4 individual 10Gb/s channels with different wavelength. Each wavelength light is collected by a discrete photo diode, and then outputted as electric data after amplified first by a TIA and a post amplifier. Figure 1 shows the functional block diagram of this product.

A single +3.3V power supply is required to power up this product. Both power supply pins VccTx and VccRx are internally connected and should be applied concurrently. As per MSA specifications the module offers 7 low speed hardware control pins (including the 2-wire serial interface): ModSelL, SCL, SDA, ResetL, LPMMode, ModPrsL and IntL.

Module Select (ModSelL) is an input pin. When held low by the host, this product responds to 2-wire serial communication commands. The ModSelL allows the use of this product on a single 2-wire interface bus – individual ModSelL lines must be used.

Serial Clock (SCL) and Serial Data (SDA) are required for the 2-wire serial bus communication interface and enable the host to access the QSFP+ memory map.

The ResetL pin enables a complete reset, returning the settings to their default state, when a low level on the ResetL pin is held for longer than the minimum pulse length. During the execution of a reset the host shall disregard all status bits until it indicates a completion of the reset interrupt. The product indicates this by posting an IntL (Interrupt) signal with the Data_Not_Ready bit negated in the memory map. Note that on power up (including hot insertion) the module should post this completion of reset interrupt without requiring a reset.

Low Power Mode (LPMMode) pin is used to set the maximum power consumption for the product in order to protect hosts that are not capable of cooling higher power modules, should such modules be accidentally inserted.

Module Present (ModPrsL) is a signal local to the host board which, in the absence of a product, is normally pulled up to the host Vcc. When the product is inserted into the connector, it completes the path to ground through a resistor on the host board and asserts the signal. ModPrsL then indicates its present by setting ModPrsL to a “Low” state.

Interrupt (IntL) is an output pin. “Low” indicates a possible operational fault or a

status critical to the host system. The host identifies the source of the interrupt using the 2-wire serial interface. The IntL pin is an open collector output and must be pulled to the Host Vcc voltage on the Host board.

Transceiver Block Diagram

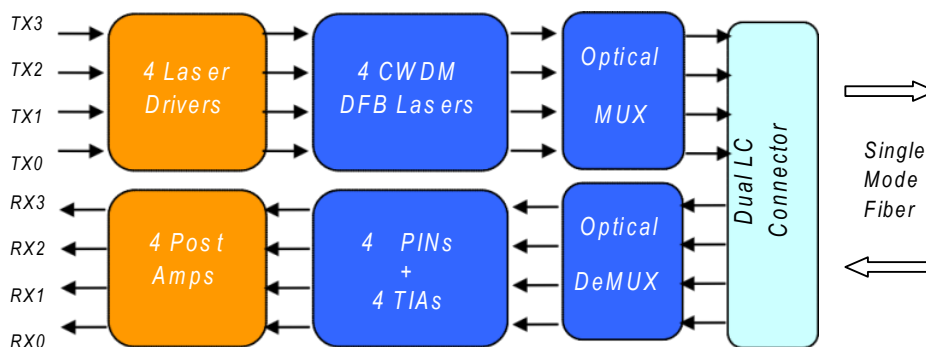

Figure 1. Transceiver Block Diagram

Pin Assignment and Description

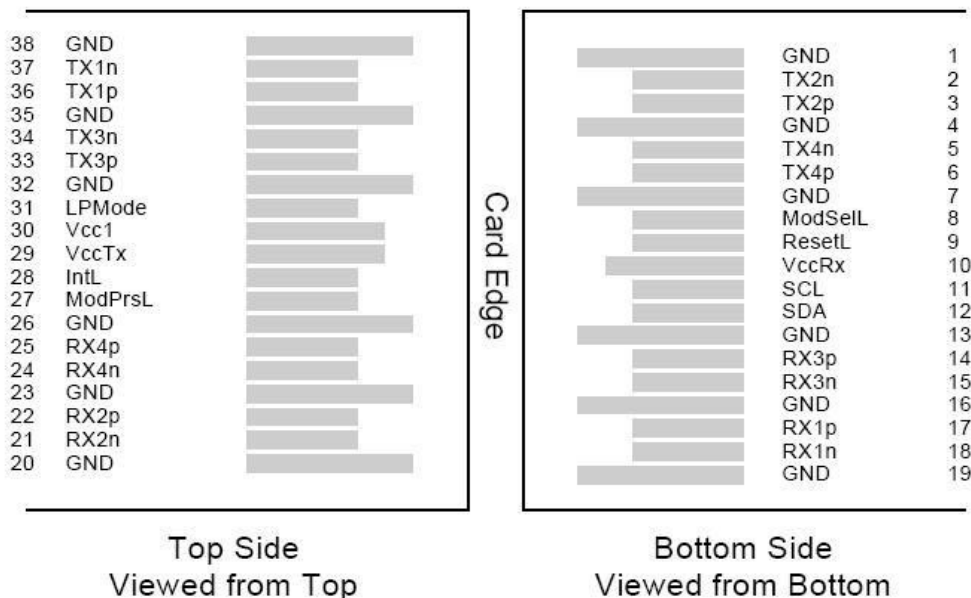

Figure 2. MSA compliant Connector

Pin Definition

PIN	Logic	Symbol	Name/Description	Notes
1		GND	Ground	1
2	CML-I	Tx2n	Transmitter Inverted Data Input	
3	CML-I	Tx2p	Transmitter Non-Inverted Data	
4		GND	Ground	1
5	CML-I	Tx4n	Transmitter Inverted Data Input	
6	CML-I	Tx4p	Transmitter Non-Inverted Data	
7		GND	Ground	1
8	LVTLL-I	ModSelL	Module Select	
9	LVTLL-I	ResetL	Module Reset	
10		VccRx	+3.3V Power Supply Receiver	2
11	LVC MOS-	SCL	2-Wire Serial Interface Clock	
12	LVC MOS-	SDA	2-Wire Serial Interface Data	
13		GND	Ground	
14	CML-O	Rx3p	Receiver Non-Inverted Data Output	
15	CML-O	Rx3n	Receiver Inverted Data Output	
		GND	Ground	1
17	CML-O	Rx1p	Receiver Non-Inverted Data Output	
18	CML-O	Rx1n	Receiver Inverted Data Output	
19		GND	Ground	1
20		GND	Ground	1
21	CML-O	Rx2n	Receiver Inverted Data Output	
22	CML-O	Rx2p	Receiver Non-Inverted Data Output	
23		GND	Ground	1
24	CML-O	Rx4n	Receiver Inverted Data Output	1
25	CML-O	Rx4p	Receiver Non-Inverted Data Output	
26		GND	Ground	1
27	LVTTL-O	ModPrsL	Module Present	
28	LVTTL-O	IntL	Interrupt	
29		VccTx	+3.3 V Power Supply transmitter	2
30		Vcc1	+3.3 V Power Supply	2
31	LVTTL-I	LPMODE	Low Power Mode	

32		GND	Ground	1
33	CML-I	Tx3p	Transmitter Non-Inverted Data Input	
34	CML-I	Tx3n	Transmitter Inverted Data Output	
35		GND	Ground	1
36	CML-I	Tx1p	Transmitter Non-Inverted Data Input	
37	CML-I	Tx1n	Transmitter Inverted Data Output	
38		GND	Ground	1

Notes:

1. GND is the symbol for signal and supply (power) common for QSFP+ modules. All are common within the QSFP+ module and all module voltages are referenced to this potential unless otherwise noted. Connect these directly to the host board signal common ground plane.
2. VccRx, Vcc1 and VccTx are the receiving and transmission power suppliers and shall be applied concurrently. Recommended host board power supply filtering is shown in Figure 3 below. Vcc Rx, Vcc1 and Vcc Tx may be internally connected within the QSFP+ transceiver module in any combination. The connector pins are each rated for a maximum current of 500mA.

Recommended Power Supply Filter

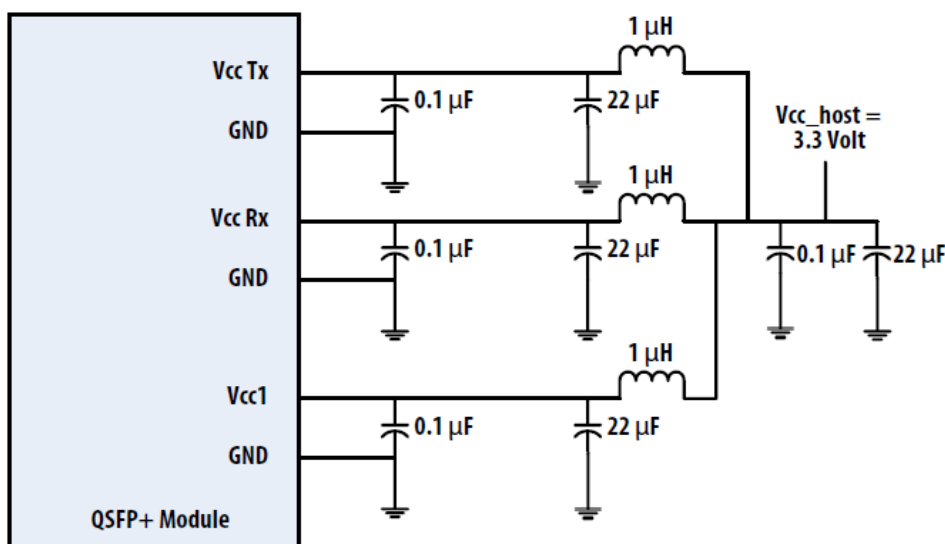

Figure 3. Recommended Power Supply Filter

Absolute Maximum Ratings

It has to be noted that the operation in excess of any individual absolute maximum ratings might cause permanent damage to this module.

Parameter	Symbol	Min	Max	Units	Notes
Storage Temperature	TS	-40	85	degC	
Operating Case Temperature	TOP	0	70	degC	
Power Supply Voltage	VCC	-0.5	3.6	V	
Relative Humidity (non-condensation)	RH	0	85	%	
Damage Threshold, each Lane	THd	3.3		dBm	

Recommended Operating Conditions and Power Supply Requirements

Parameter	Symbol	Min	Typical	Max	Units
Operating Case Temperature	TOP	0		70	degC
Power Supply Voltage	VCC	3.135	3.3	3.465	V
Data Rate, each Lane			10.3125	11.2	Gb/s
Control Input Voltage High		2		Vcc	V
Control Input Voltage Low		0		0.8	V
Link Distance with G.652	D	0.002		40	km

Electrical Characteristics

The following electrical characteristics are defined over the Recommended Operating Environment unless otherwise specified.

Parameter	Symbol	Min	Typical	Max	Units	Notes
Power Consumption				3.5	W	
Supply Current	I _{cc}			1.1	A	
Transceiver Power-on Initialization Time				2000	ms	1
Transmitter (each Lane)						
Single-ended Input Voltage Tolerance (Note 2)		-0.3		4.0	V	Referred to TP1 signal common
AC Common Mode Input Voltage Tolerance		15			mV	RMS
Differential Input Voltage Swing Threshold		50			mV _{pp}	LOSA Threshold
Differential Input Voltage Swing	V _{in,pp}	190		700	mV _{pp}	
Differential Input Impedance	Z _{in}	90	100	110	Ohm	
Differential Input Return Loss		See IEEE 802.3ba 86A.4.11			dB	10MHz-11.1GHz
J2 Jitter Tolerance	J _{t2}	0.17			UI	
J9 Jitter Tolerance	J _{t9}	0.29			UI	
Data Dependent Pulse Width Shrinkage (DDPWS) Tolerance		0.07			UI	
Eye Mask Coordinates {X1, X2 Y1, Y2}		0.11, 0.31 95, 350			UI mV	Hit Ratio = 5x10 ⁻⁵

Receiver (each Lane)						
Single-ended Output Voltage		-0.3		4.0	V	Referred to signal common
AC Common Mode Output Voltage				7.5	mV	RMS
Differential Output Voltage Swing	Vout,pp	300		850	mVpp	
Differential Output Impedance	Zout	90	100	110	Ohm	
Termination Mismatch at 1MHz				5	%	
Differential Output Return Loss		See IEEE 802.3ba 86A.4.2.1			dB	10MHz-11.1GHz
Common Mode Output Return Loss		See IEEE 802.3ba 86A.4.2.2			dB	10MHz-11.1GHz
Output Transition Time		28			ps	20% to 80%
J2 Jitter Output	Jo2			0.42	UI	
J9 Jitter Output	Jo9			0.65	UI	
Eye Mask Coordinates {X1, X2, Y1, Y2}		0.29, 0.5 150, 425			UI mV	Hit Ratio = 5x10 ⁻⁵

Notes:

1. *Power-on Initialization Time is the time from when the power supply voltages reach and remain above the minimum recommended operating supply voltages to the time when the module is fully functional.*
2. *The single ended input voltage tolerance is the allowable range of the instantaneous input signals.*

9. Optical Characteristics

Parameter	Symbol	Min	Typical	Max	Units	Notes
Wavelength Assignment	L0	1264.5	1271	1277.5	nm	
Transmitter						
Side Mode Suppression					dB	
Total Average Launch					dBm	
Average Launch Power, each Lane	PAVG	-2.7		4.5	dBm	
Optical Modulation Amplitude	POMA	0.3		5	dBm	1
Difference in Launch Power between any Two	Ptx,diff			4.7	dB	
Launch Power in OMA minus Transmitter and Dispersion Penalty (TDP), each Lane		-0.5			dBm	
TDP, each Lane	TDP			2.6	dB	
Extinction Ratio	ER				dB	
Relative Intensity Noise	RIN			-128	dB/Hz	12dB
Optical Return Loss Tolerance	TOL			20	dB	
Transmitter Reflectance	RT			-12	dB	
Transmitter Eye Mask Definition		{0.25,0.4,0.45,0.25,0.28,0.4}				
Average Launch Power OFF Transmitter, each Lane	Poff			-30	dBm	

Receiver						
Damage Threshold, each Lane	THd	3.3			dBm	2
Total Average Receive Power				4.5	dBm	
Average Receive Power, each		-21.2		-4.5	dBm	
Receiver Reflectance	RR\			-26	dB	
Receive Power (OMA), each Lane				-4	dBm	
Receiver Sensitivity (OMA), each	SEN			-19	dBm	
Stressed Receiver Sensitivity				-16.8	dBm	3
Difference in Receive Power	Prx,diff			7.5	dB	
LOS Assert	LOSA	TBD			dBm	
LOS Deassert	LOSD			-23	dBm	
LOS Hysteresis	LOSH	0.5			dB	
Receiver Electrical 3 dB upper	Fc			12.3	GHz	
Conditions of Stress Receiver Sensitivity Test (Note 4)						
Vertical Eye Closure Penalty, each			2.2		dB	
Stressed Eye J2 Jitter,		Per OTL3.4, G.8251				
Stressed Eye J9 Jitter,		Per OTL3.4, G.8251				

Notes:

1. *Even if the TDP < 0.8 dB, the OMA min must exceed the minimum value specified here.*
2. *The receiver shall be able to tolerate, without damage, continuous exposure to a modulated optical input signal having this power level on one lane. The receiver does not have to operate correctly at this input power.*
3. *Measured with conformance test signal at receiver input for BER = 1x10⁻¹².*
4. *Vertical eye closure penalty and stressed eye jitter are test conditions for measuring stressed receiver sensitivity. They are not characteristics of the receiver.*

10. Digital Diagnostic Functions

The following digital diagnostic characteristics are defined over the normal operating conditions unless otherwise specified.

Parameter	Symbol	Min	Max	Units	Notes
Temperature monitor absolute error	DMI_Temp	-3	+3	degC	Over operating temperature range
Supply voltage monitor absolute error	DMI_VCC	-0.1	0.1	V	Over full operating range
Channel RX power monitor absolute error	DMI_RX_Ch	-2	2	dB	1
Channel Bias current monitor	DMI_Ibias_Ch	-10%	10%	mA	
Channel TX power monitor	DMI_TX_Ch	-2	2	dB	1

Notes:

1. Due to measurement accuracy of different single mode fibers , there would be an additional + / - 1dB fluctuation , or a + / -3dB total accuracy.

Mechanical Dimensions

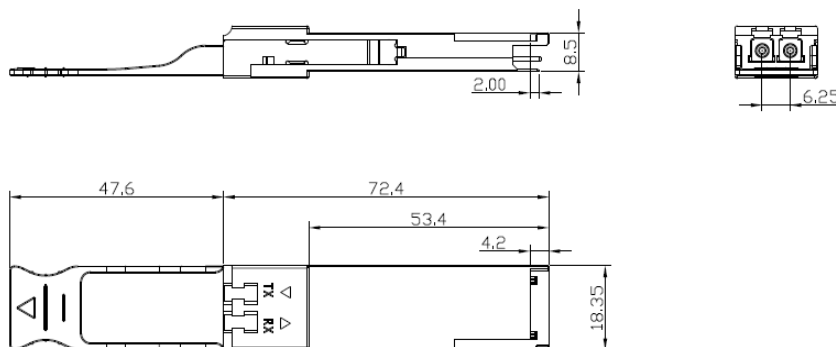

Figure 4. Mechanical Dimensions

ESD

This transceiver is specified as ESD threshold 1kV for SFI pins and 2kV for all other electrical input pins, tested per MIL-STD-883, Method 3015.4 /JESD22-A114-A (HBM). However, normal ESD precautions are still required during the handling of this module. This transceiver is shipped in ESD protective packaging. It should be removed from the packaging and handled only in an ESD protected environment.

Laser Safety

This is a Class 1 Laser Product according to IEC 60825-1:2007. This product complies with 21 CFR 1040.10 and 1040.11 except for deviations pursuant to Laser Notice No. 50, dated (June 24, 2007).

Order Information

Part Number	Product Description
NS-QSFP+40GBase-ER4	QSFP+ER4 40km optical transceiver with full real-time digital diagnostic monitoring