

NS-SFP+CxxL40D

40KM SFP+ CWDM Optical Transceiver



Особенности

- ◆ Совместимость с SFF-8431 и IEE802.3ae
- ◆ Data rate выбирается $\leq 4.25\text{Gbps}$ or 9.95Gbps to 10.3Gbps bit rates
- ◆ EML передатчик и PIN приемник
- ◆ Длины волн согласно сетке ITU-T CWDM
- ◆ Длина линии до 40km
- ◆ Низкая потребляемая мощность 1.5W Maximum
- ◆ -5°C to 70°C Рабочая температура
- ◆ Питание 3.3V
- ◆ Интерфейс диагностики и мониторинга (Diagnostic Performance Monitoring of module temperature, supply Voltages, laser bias current, transmit optical power, receive optical power)
- ◆ Соответствует RoHS

Применение

- ◆ 10GBASE-ER/EW (with/without FEC)
- ◆ 10G Fiber Channel (with/without FEC)

Описание

SFP+ER CWDM Transceiver рассчитанный на применение в 10GBASE-ER/EW, и 8.5G/10G Fiber-Channel приложениях.

Модуль состоит из 2х секций: передатчик – охлаждаемый EML laser, приемник - PIN фотодиод интегрированный в TIA. Все элементы соответствуют class I лазерной безопасности. Интерфейс цифровой диагностики (Digital diagnostics) работает в соответствии с SFF-8472, позволяет отображать в реальном времени данные по температуре, току, напряжению, уровню мощности передатчика и уровень сигнала на приеме.



Абсолютные максимальные условия окружающей среды

Parameter	Symbol	Min	Max	Unit
Supply Voltage	Vcc	-0.5	3.8	V
Storage Temperature	Tst	-40	85	°C
Relative Humidity	Rh	0	85	%

Рабочие характеристики

Parameter	Symbol	Min	Typical	Max	Unit
Supply Voltage	Vcc	3.13	3.3	3.47	V
Supply current	Icc		360	450	mA
Operating Case temperature	Tca	-5	-	70	°C
Module Power Dissipation	Pm	-	1.2	1.5	W

Примечание:

[1] Supply current is shared between VCCTX and VCCRХ.

[2] In-rush is defined as current level above steady state current requirements.

Оптический передатчик

Parameter	Symbol	Min	Typical	Max	Unit
Center Wavelength	λ_c	1464.5		1617.5	nm
Center wavelength stability	$\Delta\lambda_D$	-6.5	λ_c	6.5	nm
Optical Average Power	Po	0	-	+3	dBm
Optical OMA Power	Pom	-2.1			dBm
Side Mode Suppression Ratio	SMSR	30	-	-	dB
Optical Transmit Power (disabled)	PTX_DISABLE	-	-	-30	dBm
Extinction Ratio	ER	8.2			dB
RIN _{21OMA} [1]				-128	dB/Hz
Optical Return Loss Tolerance				21	dB

Примечание:

[1] RIN measurement is made with a return loss at 21 dB.

Электрический интерфейс

Parameter	Symbol	Min	Typical	Max	Unit
Data Rate	Mra	-	10.3	11.3	Gbps
Input differential impedance	Rim	-	100	-	Ω
Differential data Input	VtxDIFF	120	-	850	mV
Transmit Disable Voltage	VD	2.0	-	Vcc3+0.3	V
Transmit Enable Voltage	Ven	0	-	+0.8	V
Transmit Disable Assert Time	Vn	-	-	100	us

Оптический приемник

Parameter	Symbol	Min	Typical	Max	Unit
Input Operating Wavelength	λ	1260	-	1620	nm
Average receive power		-	-	-1.0	dBm
Receiver sensitivity in OMA		-	-	-14.1	dBm
Stressed receiver sensitivity in OMA[1]				-11.3	dBm
Maximum Input Power	RX-overload	-	-	-1	dBm
Reflectance	Rrx	-	-	-27	dB
Loss of Signal Asserted		-25	-	-	dBm
LOS De-Asserted		-	-	-16	dBm
LOS Hysteresis		0.5	-	-	dB

Примечание:

[1] Measured with conformance test signal for BER = 10^{-12} . The stressed sensitivity values in the table are for system level BER measurements which include the effects of CDR circuits. It is recommended that at least 0.4 dB additional margin be allocated if component level measurements are made without the effects of CDR circuits.

Электрические характеристики приемника

Parameter	Symbol	Min	Typical	Max	Unit
Data Rate	Mra	-	10.3	11.3	Gbps
Differential Output Swing	Vout P-P	350	-	850	mV
Rise/Fall Time	Tr / Tf	24	-	-	ps
Loss of Signal –Asserted	VOH	2	-	Vcc3+0.3-	V
Loss of Signal –Negated	VOL	0	-	+0.4	V



Рисунок 1. Описание PIN контактов

Pin Описание

Pin	Symbol	Name/Description
1	VEET [1]	Transmitter Ground
2	Tx_FAULT [2]	Transmitter Fault
3	Tx_DIS [3]	Transmitter Disable. Laser output disabled on high or open
4	SDA [2]	2-wire Serial Interface Data Line
5	SCL [2]	2-wire Serial Interface Clock Line
6	MOD_ABS [4]	Module Absent. Grounded within the module
7	RS0 [5]	RS0 for Rate Select: Open or Low = Module supports ≤ 4.25 Gbps High = Module supports 9.95 Gb/s to 10.3125 Gb/s
8	RX_LOS [2]	Loss of Signal indication. Logic 0 indicates normal operation
9	RS1 [5]	No connection required
10	VEER [1]	Receiver Ground
11	VEER [1]	Receiver Ground
12	RD-	Receiver Inverted DATA out. AC Coupled
13	RD+	Receiver DATA out. AC Coupled
14	VEER [1]	Receiver Ground
15	VCCR	Receiver Power Supply
16	VCCT	Transmitter Power Supply
17	VEET [1]	Transmitter Ground
18	TD+	Transmitter DATA in. AC Coupled
19	TD-	Transmitter Inverted DATA in. AC Coupled
20	VEET [1]	Transmitter Ground

Примечание:

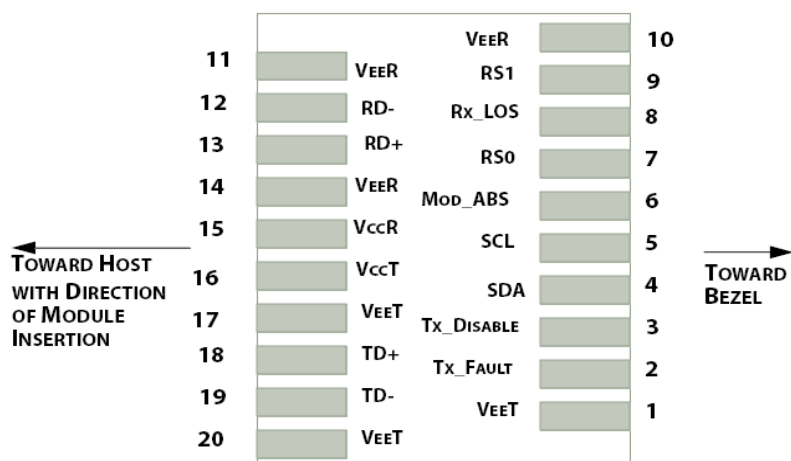
[1] Module circuit ground is isolated from module chassis ground within the module.

[2].should be pulled up with 4.7k – 10k ohms on host board to a voltage between 3.15V and 3.6V.

[3]Tx_Disable is an input contact with a 4.7 k Ω to 10 k Ω pullup to VccT inside the module.

[4]Mod_ABS is connected to VeeT or VeeR in the SFP+ module. The host may pull this contact up to Vcc_Host with a resistor in the range 4.7 k Ω to 10 k Ω . Mod_ABS is asserted "High" when the SFP+ module is physically absent from a host slot.

[5] RS0 and RS1 are module inputs and are pulled low to VeeT with > 30 k Ω resistors in the module.



Рисунок 2. Host Board Power Supply Filters Circuit



Рисунок 3. Host-Module Interface

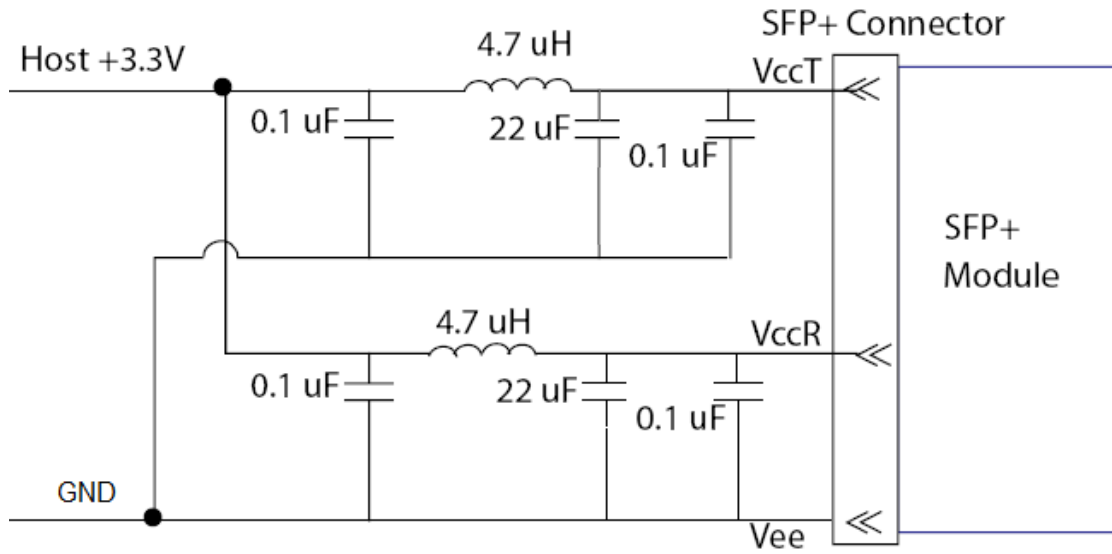

NETS

ООО «Новые Сети»
Проектирование сетей, поставка оборудования,
оптимизация и поддержка IT-инфраструктуры.
<https://newnets.ru>

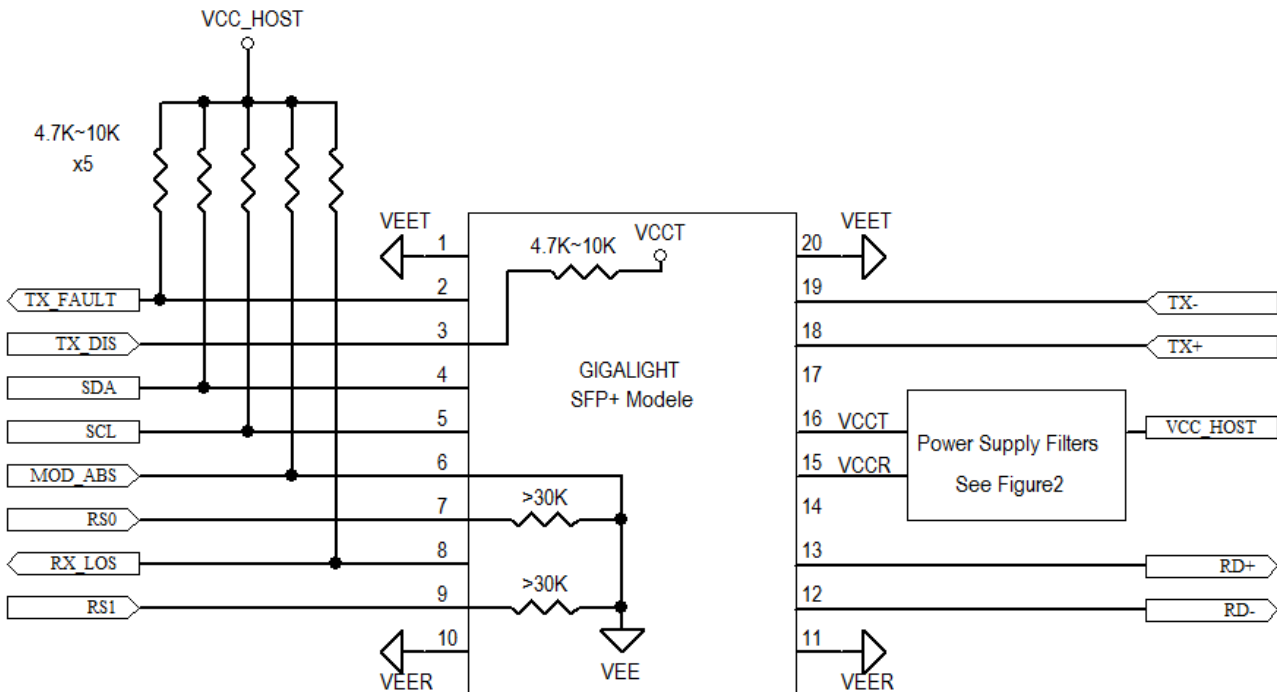
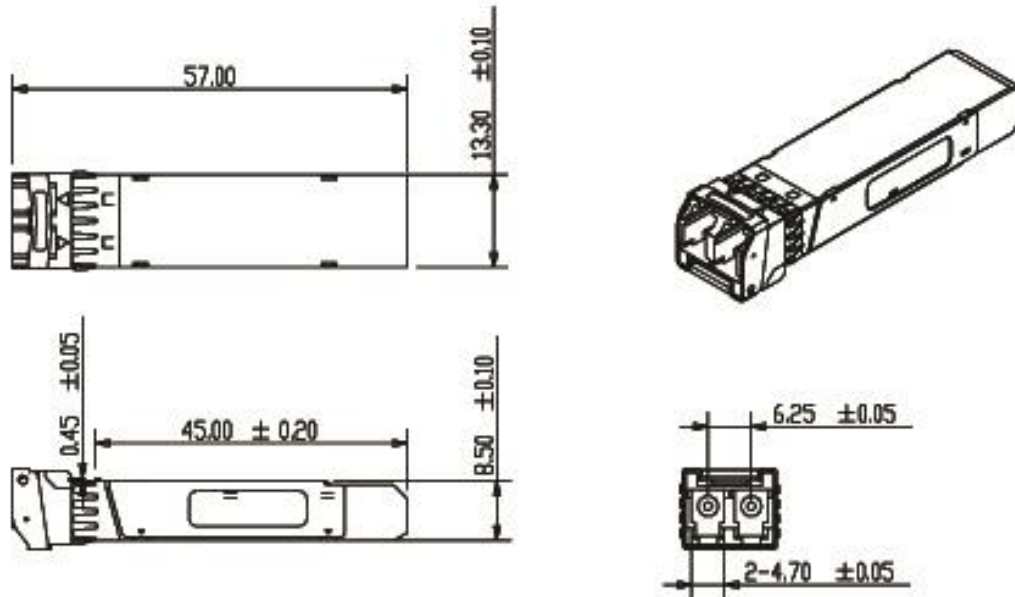

Рисунок 4. Механические характеристики

Информация для заказа

Part Number	Описание продукта
NS-SFP+C47L40D	10Gbps, 1470nm SFP+ER 40km, -5°C ~ +70°C
NS-SFP+C49L40D	10Gbps, 1490nm SFP+ER 40km, -5°C ~ +70°C
NS-SFP+C51L40D	10Gbps, 1510nm SFP+ER 40km, -5°C ~ +70°C
NS-SFP+C53L40D	10Gbps, 1530nm SFP+ER 40km, -5°C ~ +70°C
NS-SFP+C55L40D	10Gbps, 1550nm SFP+ER 40km, -5°C ~ +70°C
NS-SFP+C57L40D	10Gbps, 1570nm SFP+ER 40km, -5°C ~ +70°C
NS-SFP+C59L40D	10Gbps, 1590nm SFP+ER 40km, -5°C ~ +70°C
NS-SFP+C61L40D	10Gbps, 1610nm SFP+ER 40km, -5°C ~ +70°C