

NS-SFP+10G-LRMD

10Gbps 220m Multi Mode Datacom SFP+ Transceiver

Features

- ◆ Supports 9.95 to 10.3Gbps bit rates
- ◆ Transmission distance up to 220m (OM1 fiber)
- ◆ Hot Pluggable SFP+ footprint
- ◆ 1310nm FP transmitter, PIN photo-detector
- ◆ Digital Status monitoring Interface
- ◆ Duplex LC connector
- ◆ RoHS compliant and Lead Free
- ◆ Metal enclosure for lower EMI
- ◆ Single 3.3V power supply
- ◆ Power dissipation < 1W
- ◆ Operating case temperature: -5 to 70°C
- ◆ Compliant with FC-P1-4 800-Mx-SN-I, SFF-8431, SFF-8432 and SFF-8472



Applications

10GBASE-LRM 10G Ethernet

Legacy FDDI multimode links

Product description

NewNets's SFP+ LRM is an optical transceiver module for transmission at 1310nm over legacy multimode fiber. Supporting 10GBASE-LRM Ethernet standard make it ideally suited for 10G datacom. It's very low power consumption and its excellent EMI performance allow system design with high port density. The small form factor integrates a 1310nm Fabry-Perot (FP) laser in an LC package and a linear multimode PIN receiver. NewNets module is lead free, RoHS compliant and is designed and tested in accordance with industry safety standards.

The NewNets NS-SFP+10G-LRMD SFP+ transceiver is a linear-interface transceiver that enables, in conjunction with an Electronic Dispersion Compensation (EDC) on the host board, an IEEE802.3aq 10GBASE-LRM compliant link. The host board EDC provides correction for the severe modal dispersion that may occur during propagation through multimode fiber links, including legacy installed FDDI multimode fiber (see IEEE802.3aq for detailed information regarding fiber coverage).

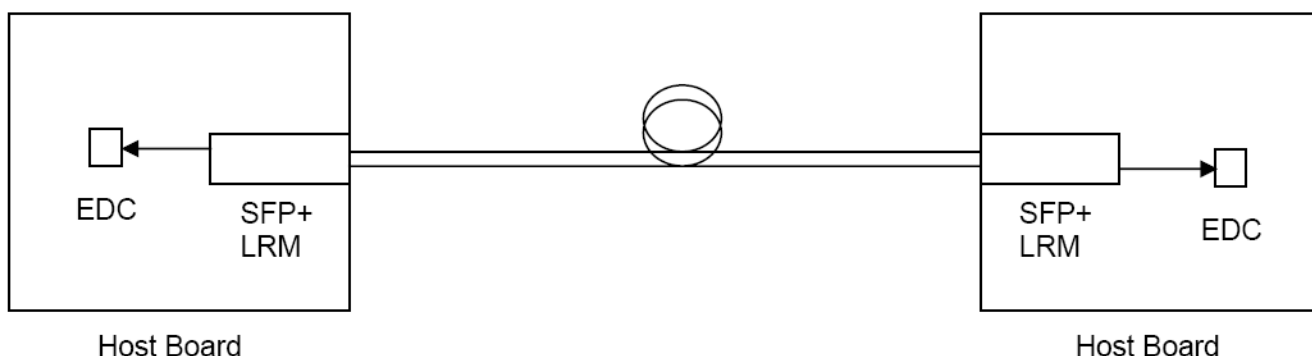

Figure 1. Block Diagram of SFP+ LRM Module on Host Board with EDC

Unlike the XFP MSA transceiver requirements, the SFP+ transceiver does not contain internal retiming circuitry, and thus some of the Transmitter Optical Characteristics stated in this data sheet require that the Host Board is compliant to the SFP+ MSA specifications. See Chapter 3 in Reference [1] for further details.

Pin definition

The SFP+ modules are hot-pluggable. Hot pluggable refers to plugging in or unplugging a module while the host board is powered. The SFP+ host connector is a 0.8 mm pitch 20 position right angle improved connector specified by SFF-8083, or stacked connector with equivalent with equivalent electrical performance. Host PCB contact assignment is shown in Figure 2 and contact definitions are given in Table 2.

SFP+ module contacts mates with the host in the order of ground, power, followed by signal as illustrated by Figure 3 and the contact sequence order listed in Table 2.

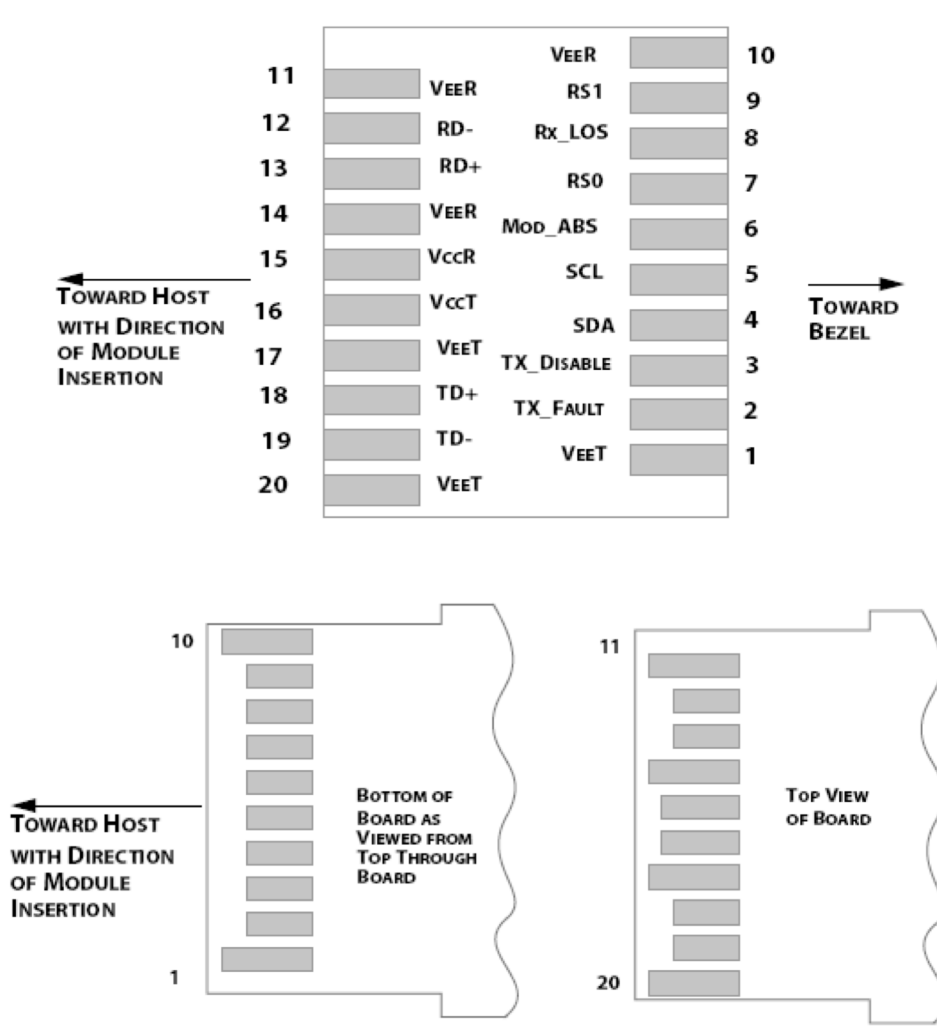

Figure 3: Module Contact Assignment

<i>Contacts</i>	<i>logic</i>	<i>Symbol</i>	<i>Power Sequence Order</i>	<i>Name/Description</i>
1		VeeT	1st	Module Transmitter Ground
2	LVTTL-O	TX_Fault	3rd	Module Transmitter Fault
3	LVTTL-I	TX_Disable	3rd	Transmitter Disable; Turns off transmitter laser output
4	LVTTL-I/O	SDA	3rd	2-wire Serial Interface Data Line (Same as MOD-DEF2 in the INF-8074i)
5	LVTTL-I/O	SCL	3rd	2-wire Serial Interface Clock (Same as MOD-DEF1 in the INF-8074i)
6		Mod_ABS	3rd	Module Absent, connected to VeeT or VeeR in the module
7	LVTTL-I	RS0	3rd	Rate Select 0, optionally controls SFP+ module receiver. When high input signaling rate > 4.25 GBd and when low input signaling rate ≤ 4.25 GBd.
8	LVTTL-O	Rx_LOS	3rd	Receiver Loss of Signal Indication (In FC designated as Rx_LOS and in Ethernet designated as Signal Detect)
9	LVTTL-I	RS1	3rd	Rate Select 1, optionally controls SFP+ transmitter. When high input signaling rate > 4.25 GBd and when low input signaling rate ≤ 4.25 GBd.
10		VeeR	1st	Module Receiver Ground
11		VeeR	1st	Module Receiver Ground
12	CML-O	RD-	3rd	Receiver Inverted Data Output
13	CML-O	RD+	3rd	Receiver Non-Inverted Data Output
14		VeeR	1st	Module Receiver Ground
15		VccR	2nd	Module Receiver 3.3 V Supply
16		VccT	2nd	Module Transmitter 3.3 V Supply
17		VeeT	1st	Module Transmitter Ground
18	CML-I	TD+	3rd	Transmitter Non-Inverted Data Input
19	CML-I	TD-	3rd	Transmitter Inverted Data Input
20		VeeT	1st	Module Transmitter Ground

Table 2: SFP+ Module PIN Definition

Absolute maximum rating

These values represent the damage threshold of the module. Stress in excess of any of the individual Absolute Maximum Ratings can cause immediate catastrophic damage to the module even if all other parameters are within Recommended Operating Conditions.

Parameters	Symbol	Min.	Max.	Unit
Power Supply Voltage	V _{CC}	0	+3.6	V
Storage Temperature	T _c	-40	+85	°C
Operating Case Temperature	T _c	0	+70	°C
Relative Humidity	RH	5	95	%

Table 3: Absolute Maximum Rating

Recommended operating environment

Recommended Operating Environment specifies parameters for which the electrical and optical characteristics hold unless otherwise noted.

Parameter	Symbol	Min.	Typical	Max	Unit
Power Supply Voltage	V _{CC}	3.135	3.300	3.465	V
Operating Case Temperature	T _c	0	25	70	°C

Table 4: Recommended Operating Environment

LOW Speed Characteristics

Parameter	Symbol	Min.	Typical	Max	Unit
Power Consumption			1.2	1.2	W
TX_Fault,RX_LOS	VOL	0		0.4	V
	VOH	Host_Vcc-0.5		Host_Vcc+0.3	V
TX_DIS	VIL	-0.3		0.8	V
	VIH	2.0		VCCT+0.3	V
RS0,RS1	VIL	-0.3		0.8	V
	VIH	2.0		VCCT+0.3	V

Electrical characteristics

Parameter	Conditions	Symbol	Min.	Typical	Max	Unit
Nominal Data Rate		VID		10.3125		Gbps
Supply Voltage		V _{CC}	3.14		3.46	V
Supply Current		I _{CC}		200	300	mA
Power Dissipation		P			1	W
Transmitter						
Input differential impedance	2	R _{in}		100		Ω
Single ended data input swing	3	V _{in,pp}	90		350	mV
Transmit Disable Voltage	4	V _D	2		V _{CC}	V
Transmit Enable Voltage		V _{EN}	V _{EE}		V _{EE} +0.8	V
Receiver						
Termination Mismatch at 1 MHz		ΔZ _M			5	%
Single Ended Output Voltage Tolerance			-0.3		4.0	V
Output AC Common Mode Voltage					7.5	mV RMS
Output Rise and Fall time (20% to 80%)	5	T _r , T _f	30			Ps
Relative Noise LRM Links with crosstalk	6	dRN _x			TBD equatio	dB/Hz
Difference Waveform Distortion Penalty	7	dWDP	per SFF-8431			dB
Differential Voltage Modulation Amplitude		V _{MA}	180		600	mV
LOS Fault	8	V _{LOS fault}	2		V _{CC} HOS _T	V
LOS Normal	8	V _{LOS norm}	V _{EE}		V _{EE} +0.8	V
Power Supply Noise Tolerance	9	V _{CC} T/V _{CC} R	per SFF-8431			mVpp

Notes:

1. Non-condensing.
2. Connected directly to TX data input pins. AC coupling from pins into laser driver IC.
3. Per SFF-8431 Rev 3.0
4. Into 100 ohms differential termination.
5. Measured with Module Compliance Test Board and OMA test pattern.
6. Crosstalk source rise/fall time (20%-80%) is 35 ps.
7. Defined with reference receiver with 14 T/2 spaced FFE taps and 5 T spaced DFE taps.
8. LOS is an open collector output. Should be pulled up with 4.7k – 10kΩ on the host board. Normal operation is logic 0; loss of signal is logic 1. Maximum pull-up voltage is 5.5V.
9. As described in Section 2.8.1, SFF-8431 Rev 3.0.

General Specifications

Parameter	Symbol	Min.	Typical	Max	Unit	Notes
Bit Rate	BR		10.3125		Gb/sec	1
Bit Error Ratio	BER			10 ⁻¹²		2
Maximum Supported Distances						
Fiber Type	1310nm OFL Bandwidth					
62.5µm	“FDDI” 160MHz/km	Lmax		220	m	3
	OM1 200MHz/km			220		
50µm	400MHz/km	Lmax		100	m	3
	OM2 500MHz/km			220		
	OM3 2000MHz/km			220		

Notes:

- 10GBASE-LRM
- Tested with a 231 – 1 PRBS
- Operating range as defined by IEEE standards. Longer reach possible depending upon link implementation.

Optical characteristics

Parameter	Symbol	Min.	Typical	Max	Unit	Notes
Transmitter						
Center Wavelength	λ_t	1260		1355	nm	
RMS spectral width	λ_{rms} @1260nm	-	-	2.4	nm	2
	λ_{rms} @1260nm-1300			2.4		
	λ_{rms} @1300nm-1355			4		
Average Optical Power	Pavg	-6.5	-	0.5	dBm	1
Extinction Ratio	ER	3.5	-	-	dB	
Optical Modulation Amplitude (OMA)	POMA	-4.5		+1.5	dBm	
Peak Launch Power	PMAX			3	dBm	
Transmitter Waveform Dispersion Penalty	TWDP			4.7	dB	3
Average Launch power of OFF transmitter	POFF			-30	dBm	

Uncorrelated Jitter [rms]	T_{Xj}			0.033	UI	
Encircled Flux	<5 μ m	30			%	
	<11 μ m	81				
Transmitter Reflectance				-12	dB	
Optical Return Loss Tolerance		20			dB	
Relative Intensity Noise	R_{in}			-128	dB/Hz	
Receiver						
Comprehensive Stressed Receiver Sensitivity (OMA) @ 10.3125Gb/s	Precursor	-	-	-6.5	dBm	5
	Symmetrical			-6	dBm	
	Postcursor			-6.5	dBm	
LOS Assert	LosA	-30	-		dBm	
LOS De-assert	LosD			-11	dBm	
Overload	P_{MAX}	+1.5	-		dBm	4
Receiver Reflectance		-	-	-12	dB	
LOS Hysteresis		0.5			dB	

Notes:

1. Average power figures are informative only, per IEEE802.3aq
2. Maximum RMS spectral width as specified by Figure 3
3. Optical Eye Mask requires the host board to be SFF-8431 compliant. Optical eye mask per IEEE802.3aq.
4. TWDP figure requires the host board to be SFF-8431 compliant. TWDP is calculated using the Matlab code provided in clause 68.6.6.2 of IEEE802.3aq
5. Receiver overload specified in OMA and under the worst comprehensive stressed condition.
6. Conditions of stressed receiver tests per IEEE802.3aq. CSRS testing requires the host board to be SFF-8431 compliant.

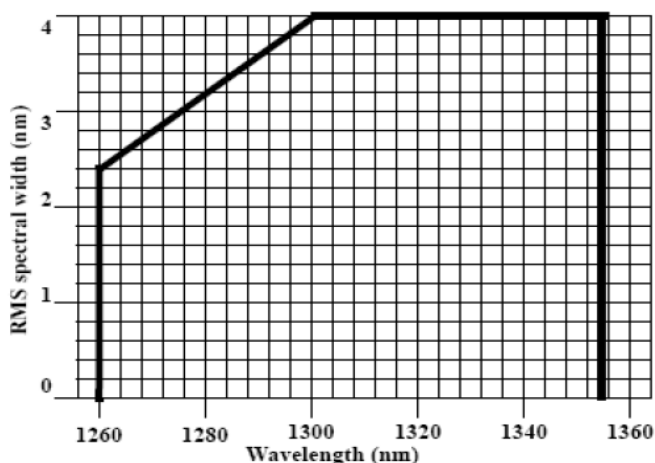

Figure 3
Transmitter Maximum RMS Spectral Width

Digital Diagnostic Functions

The following digital diagnostic characteristics are defined over the Recommended Operating Environment unless otherwise specified. It is compliant to SFF8472 Rev9.2 with internal calibration mode. For external calibration mode please contact our sales staff.

Parameter	Symbol	Min.	Max	Unit	Notes
Accuracy					
Transceiver Temperature	DMI_Temp	-3	+3	degC	Over operating temp
TX Output optical power	DMI_TX	-3	+3	dB	
RX Input optical power	DMI_RX	-3	+3	dB	-3dBm to -12dBm range
Transceiver Supply voltage	DMI_VCC	-0.08	+0.08	V	Full operating range
Bias current monitor	DMI_Ibias	-10%	10%	mA	
Dynamic Range Accuracy					
Transceiver Temperature	DMI_Temp	-5	70	degC	
TX Output optical power	DMI_TX	-9	-1	dBm	
RX Input optical power	DMI_RX	-18	0	dBm	
Transceiver Supply voltage	DMI_VCC	3.0	3.6	V	
Bias current monitor	DMI_Ibias	0	16	mA	

Control and status I/O timing characteristics

Timing characteristics of control and status I/O are included in Table 8, which is also defined in SFF-8431.

<i>Parameter</i>	<i>Symbol</i>	<i>Min.</i>	<i>Max.</i>	<i>Unit</i>	<i>Conditions</i>
TX_Disable assert time	t_off		100	µs	rising edge of TX_Disable to fall of output signal below 10% of nominal
TX_Disable negate time	t_on		2	ms	Falling edge of Tx_Disable to rise of output signal above 90% of nominal. This only applies in normal operation, not during start up or fault recovery.
Time to initialize 2-wire interface	t_2w_start_up		300	ms	From power on or hot plug after the supply meeting Table 8 .
Time to initialize	t_start_up		300	ms	From power supplies meeting Table 8 or hot plug or Tx disable negated during power up, or Tx_Fault recovery, until non-cooled power level I part (or non-cooled power level II part already enabled at power level II for Tx_Fault recovery) is fully operational.
Time to initialize cooled module	t_start_up_cooled		90	s	From power supplies meeting Table 8 or hot plug, or Tx disable negated during power up or Tx_Fault recovery, until cooled power level I part (or cooled power level II part during fault recovery) is fully operational.
Time to Power Up to Level II	t_power_level2		300	ms	From falling edge of stop bit enabling power level II until non-cooled module is fully operational
Time to Power Down from Level II	t_power_down		300	ms	From falling edge of stop bit disabling power level II until module is within power level I requirements
TX_Fault assert	TX_Fault_on		1	ms	From occurrence of fault to assertion of TX_Fault
TX_Fault assert for cooled module	TX_Fault_on_cooled		50	ms	From occurrence of fault to assertion of TX_Fault
TX_Fault Reset	t_reset	10		µs	Time TX_Disable must be held high to reset TX_Fault
RS0, RS1 rate select timing for FC	t_RS0_FC, RS1_FC		500	µs	From assertion till stable output
RS0, RS1 rate select timing non FC	t_RS0, t_RS1		10	ms	From assertion till stable output
Rx_LOS assert delay	t_los_on		100	µs	From occurrence of loss of signal to assertion of Rx_LOS
Rx_LOS negate delay	t_los_off		100	µs	From occurrence of presence of signal to negation of Rx_LOS

Table 8: Timing Characteristics

Mechanical

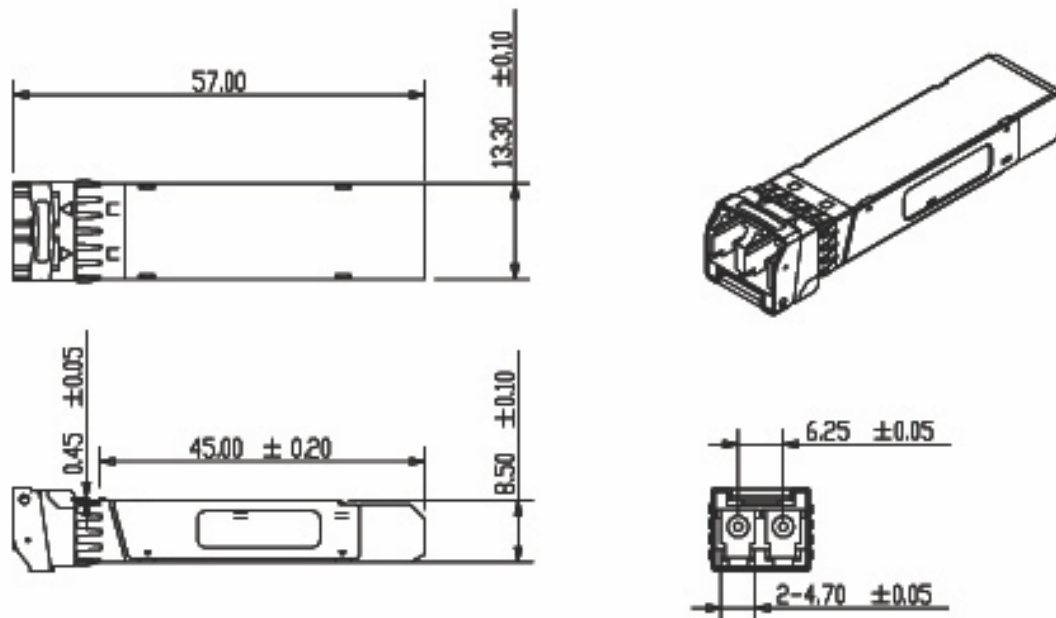

Table 9: Key Mechanical Dimensions

ESD

This transceiver is specified as ESD threshold 2kV for all electrical input pins, tested per MIL-STD-883, Method 3015.4 /JESD22-A114-A (HBM). However, normal ESD precautions are still required during the handling of this module. This transceiver is shipped in ESD protective packaging. It should be removed from the packaging and handled only in an ESD protected environment.

LASER SAFTY

This is a Class 1 Laser Product according to IEC 60825-1:1993+A1:1997+A2:2001. This product complies with 21 CFR 1040.10 and 1040.11 except for deviations pursuant to Laser Notice No. 50, dated (July 26, 2001)

Ordering information

Part Number	Product Description
NS-SFP+10G-LRMD	1310nm, 10.3125Gpbs, Multi-Mode 220m, -5°C ~ +70°C