

NS-SFP+CxxL80D

80KM SFP+ CWDM Optical Transceiver

Features

- ◆ Compliant with SFF-8431 and IEEE802.3ae
- ◆ Data rate selectable ≤ 4.25 Gbps or 9.95Gbps to 10.3Gbps bit rates
- ◆ Cooled EML transmitter and APD receiver
- ◆ Wavelength selectable to ITU-T standards covering CWDM grid wavelengths
- ◆ 1470nm~1570nm link length up to 80km (1600ps/nm)
- ◆ 1590nm~1610nm link length up to 70km (1400ps/nm)
- ◆ Low Power Dissipation 2W Maximum
- ◆ -5°C to 70°C Operating Case Temperature
- ◆ Single 3.3V power supply
- ◆ Diagnostic Performance Monitoring of module temperature, supply Voltages, laser bias current, transmit optical power, receive optical power
- ◆ RoHS compliant and lead free



Applications

- ◆ 10GBASE-ZR

Description

NewNets SFP+ZR CWDM Transceiver is designed for 10GBASE-ZR applications.

The transceiver consists of two sections: The transmitter section incorporates a cooled EML laser. And the receiver section consists of a APD photodiode integrated with a TIA. All modules satisfy class I laser safety requirements. Digital diagnostics functions are available via a 2-wire serial interface, as specified in SFF-8472, which allows real-time access to device operating parameters such as transceiver temperature, laser bias current, transmitted optical power, received optical power and transceiver supply voltage.

Absolute Maximum Ratings

Parameter	Symbol	Min	Max	Unit
Supply Voltage	Vcc	-0.5	3.8	V
Storage Temperature	Tst	-40	85	°C
Relative Humidity	Rh	0	85	%

Operating Conditions

Parameter	Symbol	Min	Typical	Max	Unit
Supply Voltage	Vcc	3.13	3.3	3.47	V
Supply current	Icc		420	610	mA
Operating Case temperature	Tca	-5	-	70	°C
Module Power Dissipation	Pm	-	1.4	2	W

Notes:

[1] Supply current is shared between VCCTX and VCCRX.

[2] In-rush is defined as current level above steady state current requirements.

Transmitter Specifications – Optical

Parameter	Symbol	Min	Typical	Max	Unit
Center Wavelength	λ_c	1464.5		1617.5	nm
Center wavelength stability	$\Delta\lambda_D$	-6.5	λ_c	6.5	nm
Optical Average Power	Po	0	-	+3	dBm
Optical OMA Power	Pom	-2.1			dBm
Side Mode Suppression Ratio	SMSR	30	-	-	dB
Optical Transmit Power (disabled)	PTX_DISABLE	-	-	-30	dBm
Extinction Ratio	ER	8.2		-	dB
RIN _{21OMA} [1]				-128	dB/Hz
Optical Return Loss Tolerance				21	dB

Notes:

[1] RIN measurement is made with a return loss at 21 dB.

Transmitter Specifications – Electrical

Parameter	Symbol	Min	Typical	Max	Unit
Data Rate	Mra	-	10.3	11.3	Gbps
Input differential impedance	Rim	-	100	-	Ω
Differential data Input	VtxDIFF	120	-	850	mV
Transmit Disable Voltage	VD	2.0	-	Vcc3+0.3	V
Transmit Enable Voltage	Ven	0	-	+0.8	V
Transmit Disable Assert Time	Vn	-	-	100	us

Receiver Specifications – Optical

Parameter	Symbol	Min	Typical	Max	Unit
Input Operating Wavelength	λ	1260	-	1620	nm
Average receive power		-	-	-1.0	dBm
Receiver sensitivity		-	-	-24	dBm
Maximum Input Power	RX-overload	-	-	-7	dBm
Reflectance	Rrx	-	-	-27	dB
Loss of Signal Asserted		-35	-	-	dBm
LOS De-Asserted		-	-	-30	dBm
LOS Hysteresis		0.5	-	-	dB

Receiver Specifications – Electrical

Parameter	Symbol	Min	Typical	Max	Unit
Data Rate	Mra	-	10.3	11.3	Gbps
Differential Output Swing	Vout P-P	350	-	850	mV
Rise/Fall Time	Tr / Tf	24	-	-	ps
Loss of Signal –Asserted	VOH	2	-	Vcc3+0.3-	V
Loss of Signal –Negated	VOL	0	-	+0.4	V

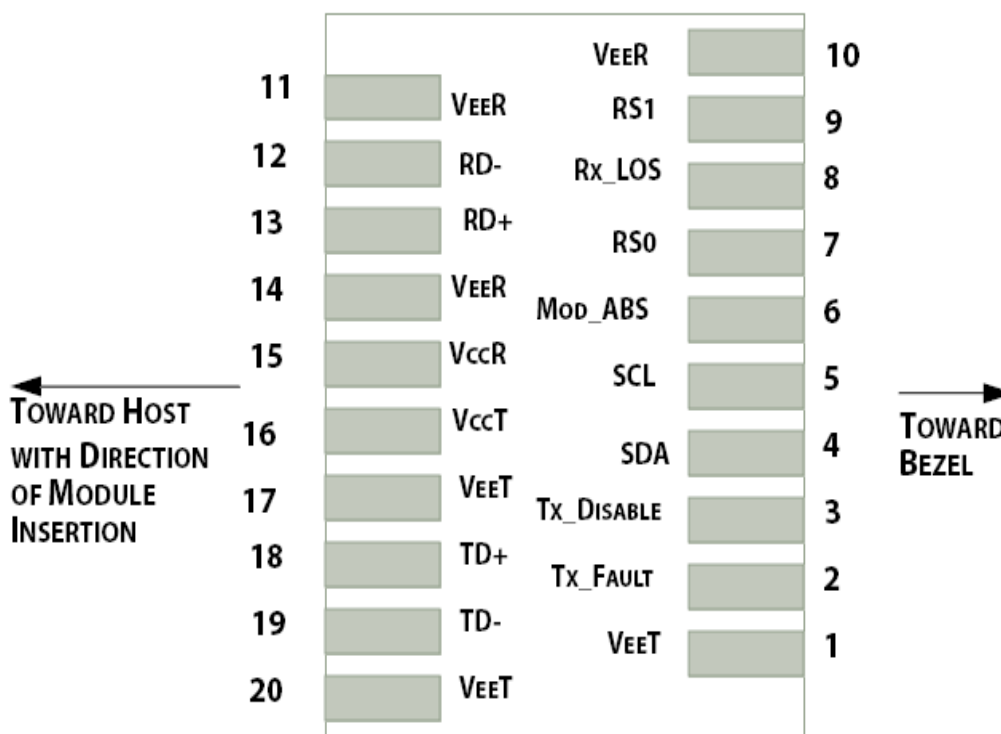

Figure1. Electrical Pin-out Details

Pin Descriptions

Pin	Symbol	Name/Description
1	VEET [1]	Transmitter Ground
2	Tx_FAULT [2]	Transmitter Fault
3	Tx_DIS [3]	Transmitter Disable. Laser output disabled on high or open
4	SDA [2]	2-wire Serial Interface Data Line
5	SCL [2]	2-wire Serial Interface Clock Line
6	MOD_ABS [4]	Module Absent. Grounded within the module
7	RS0 [5]	RS0 for Rate Select: Open or Low = Module supports ≤ 4.25 Gbps High = Module supports 9.95 Gb/s to 10.3125 Gb/s
8	RX_LOS [2]	Loss of Signal indication. Logic 0 indicates normal operation
9	RS1 [5]	No connection required
10	VEER [1]	Receiver Ground
11	VEER [1]	Receiver Ground
12	RD-	Receiver Inverted DATA out. AC Coupled
13	RD+	Receiver DATA out. AC Coupled
14	VEER [1]	Receiver Ground
15	VCCR	Receiver Power Supply
16	VCCT	Transmitter Power Supply
17	VEET [1]	Transmitter Ground
18	TD+	Transmitter DATA in. AC Coupled
19	TD-	Transmitter Inverted DATA in. AC Coupled
20	VEET [1]	Transmitter Ground

Notes:

[1] Module circuit ground is isolated from module chassis ground within the module.

[2] Should be pulled up with 4.7k – 10k ohms on host board to a voltage between 3.15V and 3.6V.

[3] Tx_Disable is an input contact with a 4.7 k Ω to 10 k Ω pullup to VccT inside the module.

[4] Mod_ABS is connected to VeeT or VeeR in the SFP+ module. The host may pull this contact up to Vcc_Host with a resistor in the range 4.7 k Ω to 10 k Ω . Mod_ABS is asserted “High” when the SFP+ module is physically absent from a host slot.

[5] RS0 and RS1 are module inputs and are pulled low to VeeT with > 30 k Ω resistors in the module.

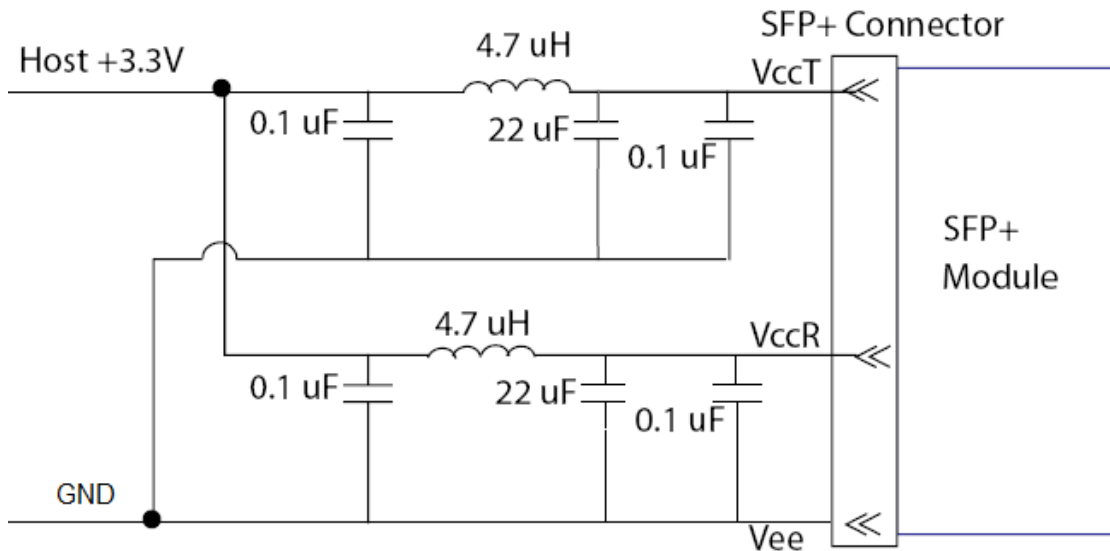

Figure2. Host Board Power Supply Filters Circuit

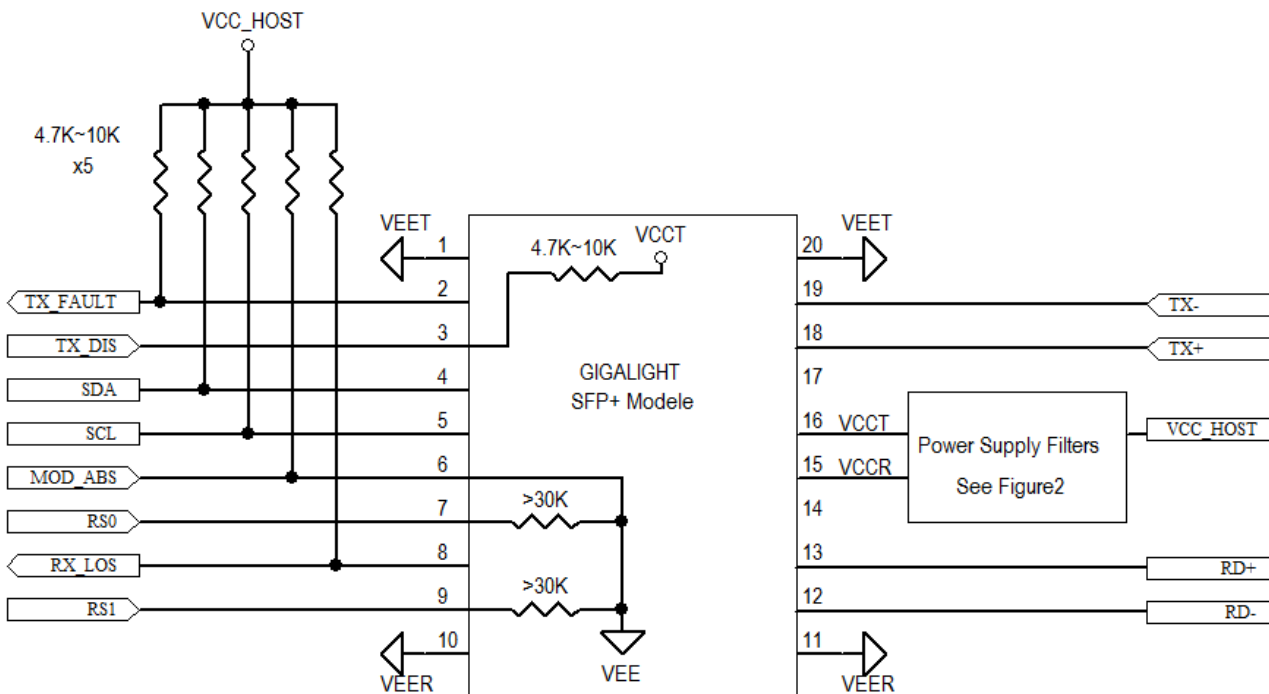

Figure3. Host-Module Interface

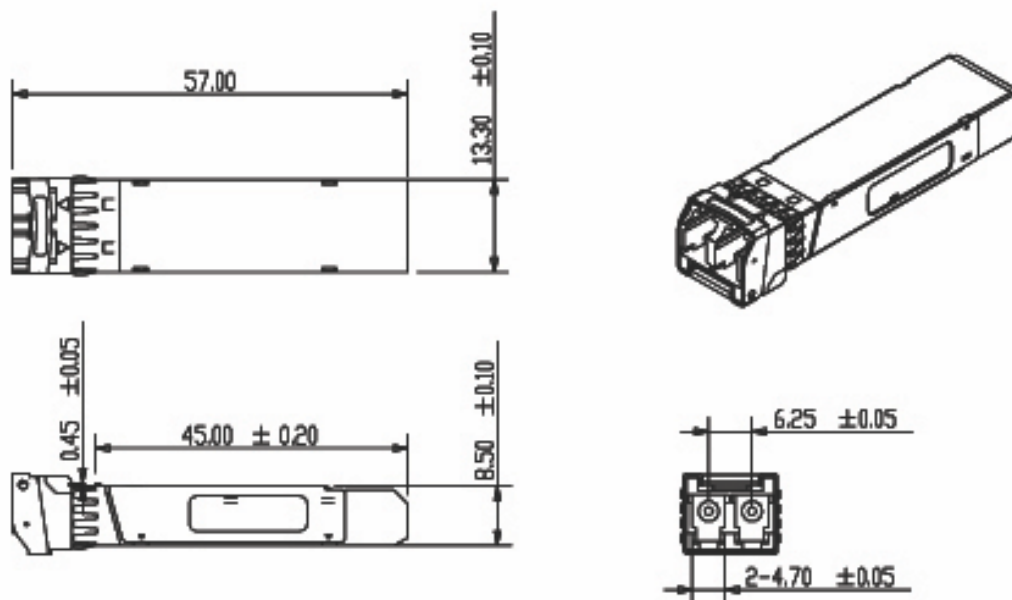

Figure4. Mechanical Specifications

Ordering information

Part Number	Product Description
NS-SFP+CxxL80D	10Gbps, 1470nm SFP+ZR 80km, -5°C ~ +70°C
	10Gbps, 1490nm SFP+ZR 80km, -5°C ~ +70°C
	10Gbps, 1510nm SFP+ZR 80km, -5°C ~ +70°C
	10Gbps, 1530nm SFP+ZR 80km, -5°C ~ +70°C
	10Gbps, 1550nm SFP+ZR 80km, -5°C ~ +70°C
	10Gbps, 1570nm SFP+ZR 80km, -5°C ~ +70°C
	10Gbps, 1590nm SFP+ZR 70km, -5°C ~ +70°C
	10Gbps, 1610nm SFP+ZR 70km, -5°C ~ +70°C